

TORQUE AND ANGLE CONTROL SCREWDRIVERS

MD Series





PRODUCTIVE SOLUTIONS

As an industrial process expert, we help you meet your challenges.

Productivity, safety, quality, industry 4.0 are themes on which we can offer you our expertise and our solutions. Whether in the field of assembly technology, machining or welding, our dedicated and specialised teams accompany your progress and recommend solutions and equipment to reach performance levels in line with your industrial strategy.



Certified quality

From design to commissioning, DOGA guarantees the quality of his equipments and services according to ISO 9001: 2015 certification.

5 reasons to trust us



Expertise

Our field experts propose you solutions adapted to your environment and specific needs.



Innovation

By developing the products and the services of tomorrow, we offer you new perspectives or prospects.



Performance

Our high added value solutions improve your performances and guarantee the final quality of the production.



Commitment

Aware of your objectives, we commit ourselves to helping you to reach them.



Reliability

Our organization which has been ISO 9001 certified since 1996, is the guarantee of your satisfaction.



ASSEMBLY TECHNOLOGY

As world class assembly technology player, we manufacture and market equipments and solutions for the assembly industry which contribute to the improvement of your manufacturing quality and productivity.

Our assembly, ergonomics and traceability solutions contribute to enhancing your productivity, controlling your process quality and meet the requirements of industry 4.0.

We offer products designed to last and high value-added services by relying on our teams know-how and expertise : design, production, installation, start-up, training and maintenance. We support you locally thanks to our worldwide presence through our subsidiaries and our specialized distribution network.



Contact us

@ international@dogas.com

+33 1 30 66 41 41

www.dogasassembly.com

SUMMARY

TORQUE AND ANGLE CONTROL SCREWDRIVERS

MD Serie

▶ A WIDE RANGE OF TORQUE AND ANGLE CONTROL TOOLS.....	4
▶ STRAIGHT SCREWDRIVERS - MD SERIES	6
▶ PISTOL SCREWDRIVERS - MDP SERIES.....	7
▶ ANGLE HEAD SCREWDRIVERS - MDH SERIES.....	8
▶ SPINDLES FOR AUTOMATION - MDA SERIES.....	9
▶ MDC CONTROLLERS	10
▶ PARAMON FREE PC SOFTWARE	16
▶ ACCESSORIES AND CALIBRATION	17
▶ ADDITIONAL PRODUCTS	20
▶ OUR SERVICES	23

A WIDE RANGE OF ELECTRIC TOOLS WITH TORQUE AND ANGLE CONTROL



PRODUCTIVITY

- Self-learning mode determines the best parameters to provide the best torque accuracy with the highest possible speed.
- Highest MTBF thanks to its high quality DC motor.



MANUFACTURING QUALITY

- Extreme torque repeatability thanks to innovative shut off management (Torque rising time - Torque holding time) according to joint features.
- All errors checked thanks to Poka Yoke functions and AC/TM - TC/AM tightening strategies.

Models overview

Among this wide range, you will find the screwdriver model and ergonomics that will allow you to optimize your workstation.



Straight screwdrivers MD series

- From 0.03 to 49 Nm
- Lever start or push to start



Pistol screwdrivers MDP series

- From 0.1 to 49 Nm
- Trigger start
- Bottom or top exit cable



Angle head screwdrivers MDH series

- From 0.2 to 49 Nm



Fixtured spindles for automation MDA series

- From 0.01 to 49 Nm
- Remote start through I/O of the controller or communication protocol

SPECIAL MICROTORQUE

MD Series *mini*



Straight screwdrivers and spindles MD series mini

- From 0.01 to 0.2 Nm
- Lever start or remote start

Models specifications

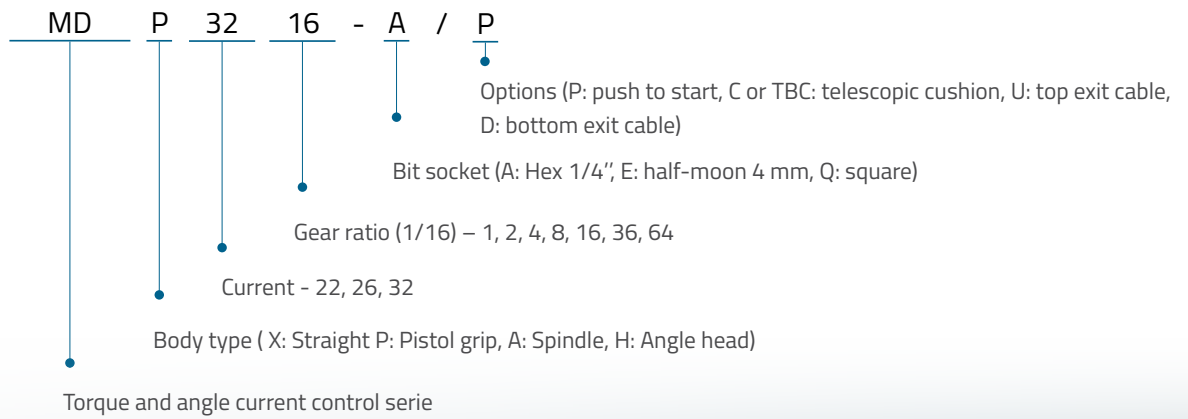

STRAIGHT SCREWDRIVERS - MD SERIES

Compact, lightweight and ergonomic, the MD torque and angle straight screwdrivers cover a wide range of torques from 0.01 to 49 Nm.

Precise and robust, they are designed for high-speed vertical tightening operations requiring accuracy and traceability.



Lever start

Designation	Torque (min Nm)	Torque (max Nm)	Speed (rpm)	Weight (gr)	Bit socket	Controller	Code
MD2201-E mini	0.01	0.07	150 - 2 000	220	Half-moon	MDC26s	4-1000205
MD2203-E mini	0.04	0.2	100 - 1 000	220	Half-moon		4-1000206
MD2601-A	0.03	0.39	150 - 2 000	430	Hex 1/4"	MDC-26	4-1050500
MD2601-E	0.03	0.39	150 - 2 000	430	Half-moon		4-1050501
MD2602-A	0.05	0.68	150 - 2 000	435	Hex 1/4"		4-1050502
MD2602-E	0.05	0.68	150 - 2 000	435	Half-moon		4-1050503
MD2604-A	0.2	1.37	150 - 1 500	515	Hex 1/4"		4-1050504
MD2611-A	0.4	3.3	100 - 900	545	Hex 1/4"		4-1090138
MD2616-A	0.5	4.9	100 - 620	545	Hex 1/4"		4-1050506
MD3201-A	0.1	1.17	150 - 2 000	675	Hex 1/4"		MDC-32
MD3202-A	0.2	2.15	150 - 2 000	685	Hex 1/4"	4-1050508	
MD3204-A	0.4	3.9	150 - 1 500	850	Hex 1/4"	4-1050509	
MD3208-A	0.7	7.3	50 - 950	900	Hex 1/4"	4-1050660	
MD3211-A	1	8.8	50-690	910	Hex 1/4"	4-1050510	
MD3216-A	2	13.7	50-470	905	Hex 1/4"	4-1050511	
MD3236-Q	4	27	50-210	1 340	SQ 3/8"	4-1050512	
MD3264-Q	8	49	50-115	1 330	SQ 1/2"	4-1050513	

Delivered without tool cable.

Push to start

Designation	Torque (min Nm)	Torque (max Nm)	Speed (rpm)	Weight (gr)	Bit socket	Controller	Code
MD2602-A/P	0.05	0.68	150 - 2 000	435	Hex 1/4"	MDC-26	4-1050652
MD2602-E/P	0.05	0.68	150 - 2000	435	Half-moon		4-1050653
MD2604-A/P	0.2	1.37	150 - 1 500	515	Hex 1/4"		4-1050654
MD2611-A/P	0.4	3.3	100 - 900	545	Hex 1/4"		4-1050655
MD2616-A/P	0.5	4.9	100 - 620	545	Hex 1/4"		4-1050656
MD3201-A/P	0.1	1.17	150 - 2 000	675	Hex 1/4"	MDC-32	4-1050657
MD3202-A/P	0.2	2.15	150 - 2 000	685	Hex 1/4"		4-1050658
MD3204-A/P	0.4	3.9	150 - 1 500	850	Hex 1/4"		4-1050659
MD3211-A/P	1	8.8	50 - 690	910	Hex 1/4"		4-1050745
MD3216-A/P	2	13.7	50 - 470	905	Hex 1/4"		4-1050746

Delivered without tool cable.

PISTOL SCREWDRIVERS - MDP SERIES

Compact, lightweight and ergonomic, the MDP torque and angle pistol screwdrivers cover a wide range of torques from 0,1 to 49 Nm.

Ideal for horizontal tightening operations, they are accurate, robust and designed to meet your production rates and repeatability requirements.



MDP 32

Top exit cable

Designation	Torque (min Nm)	Torque (max Nm)	Speed (rpm)	Weight (gr)	Bit socket	Controller	Code
MDP3201-A/U	0.1	1.17	150 - 2 000	735	Hex 1/4"	MDC-32	4-1050514
MDP3202-A/U	0.2	2.15	150 - 2 000	745	Hex 1/4"		4-1050516
MDP3204-A/U	0.4	3.9	150 - 1 500	910	Hex 1/4"		4-1050518
MDP3208-A/U	0.7	7.3	50-950	950	Hex 1/4"		4-1050754
MDP3211-A/U	1	8.8	50 - 690	970	Hex 1/4"		4-1050520
MDP3216-A/U	2	13.7	50 - 470	965	Hex 1/4"		4-1050522
MDP3236-Q/U	4	27	50 - 210	1 400	SQ 3/8		4-1050524
MDP3264-Q/U	8	49	50 - 115	1 410	SQ 1/2		4-1050526

Delivered without tool cable.

Bottom exit cable

Designation	Torque (min Nm)	Torque (max Nm)	Speed (rpm)	Weight (gr)	Bit socket	Controller	Code
MDP3201-A/D	0.1	1.17	150 - 2 000	735	Hex 1/4"	MDC-32	4-1050515
MDP3202-A/D	0.2	2.15	150 - 2 000	745	Hex 1/4"		4-1050517
MDP3204-A/D	0.4	3.9	150 - 1 500	910	Hex 1/4"		4-1050519
MDP3208-A/D	0.7	7.3	50 - 950	950	Hex 1/4"		4-1050669
MDP3211-A/D	1	8.8	50 - 690	970	Hex 1/4"		4-1050521
MDP3216-A/D	2	13.7	50 - 470	965	Hex 1/4"		4-1050523
MDP3236-Q/D	4	27	50 - 210	1 400	SQ 3/8		4-1050525
MDP3264-Q/D	8	49	50 - 115	1 410	SQ 1/2		4-1050527

Delivered without tool cable.

ANGLE HEAD SCREWDRIVERS - MDH SERIES

Compact, balanced and ergonomic, the MDH torque and angle nutrunners cover a wide range of torques from 0.2 to 49 Nm.

Their angle heads are ideal for torque and angle tightening operations in hard-to-reach areas.

They are designed to meet high production rates requiring accuracy and traceability.



Designation	Torque (min Nm)	Torque (max Nm)	Speed (rpm)	Weight (gr)	Bit socket	Controller	Code
MDH2604-A	0.2	1.37	150 - 1 500	875	Hex 1/4"	MDC-26	4-1050528
MDH2611-A	0.4	3.3	100 - 900	905	Hex 1/4"		4-1050529
MDH2616-A	0.5	4.9	100 - 620	900	Hex 1/4"		4-1050530
MDH3201-A	0.1	1.17	150 - 2 000	1 085	Hex 1/4"	MDC-32	4-1050531
MDH3202-A	0.2	2.15	150 - 2 000	1 095	Hex 1/4"		4-1050532
MDH3204-A	0.4	3.9	150 - 1 500	1 260	Hex 1/4"		4-1050533
MDH3208-A	0.7	7.3	50 - 950	1 300	Hex 1/4"		4-1050755
MDH3211-A	1	8.8	50 - 690	1 320	Hex 1/4"		4-1050534
MDH3216-A	2	13.7	50 - 470	1 315	Hex 1/4"		4-1050535
MDH3236-Q	4	27	50 - 210	1 940	SQ 3/8"		4-1050536
MDH3264-Q	8	49	50 - 115	1 930	SQ 1/2"		4-1050537

Delivered without tool cable.

SPINDLES FOR AUTOMATION - MDA SERIES

Compact and robust, the MDA torque and angle straight spindles cover a wide torque range from 0.01 to 49 Nm.

They are designed to be integrated into your automated systems and meet your production rates.



MDA 32
without telescopic
cushion



MDA 32
with telescopic
cushion



MDA 22 mini
for microtorque

Without telescopic cushion

Designation	Torque (min Nm)	Torque (max Nm)	Speed (rpm)	Weight (gr)	Bit socket	Controller	Code
MDA2601-E	0.03	0.39	150 - 2 000	525	Half-moon Ø 4	MDC-26	4-1050539
MDA2602-E	0.05	0.68	150 - 2 000	530	Half-moon Ø 4		4-1050540
MDA2602-A	0.05	0.68	150 - 2 000	530	Hex 1/4"		4-1050541
MDA2604-A	0.2	1.37	150 - 1 500	610	Hex 1/4"		4-1050542
MDA2611-A	0.4	3.3	100 - 900	640	Hex 1/4"		4-1050543
MDA2616-A	0.5	4.9	100 - 620	640	Hex 1/4"		4-1050544
MDA3201-A	0.1	1.17	150 - 2 000	770	Hex 1/4"	MDC-32	4-1050545
MDA3202-A	0.2	2.15	150 - 2 000	780	Hex 1/4"		4-1050546
MDA3204-A	0.4	3.9	150 - 1 500	945	Hex 1/4"		4-1050547
MDA3208-A	0.7	7.3	50 - 950	1 000	Hex 1/4"		4-1050756
MDA3211-A	1	8.8	50 - 690	1 005	Hex 1/4"		4-1050548
MDA3216-A	2	13.7	50 - 470	1 000	Hex 1/4"		4-1050549
MDA3236-Q	4	27	50 - 210	1 550	SQ 3/8"		4-1050550
MDA3264-Q	8	49	50 - 115	1 560	SQ 1/2"		4-1050551

Delivered without tool cable.

With built-in telescoping cushion

Designation	Torque (min Nm)	Torque (max Nm)	Speed (rpm)	Weight (gr)	Stroke	Bit Socket	Controller	Code
MDA2201-E+C mini	0.01	0.07	150 - 2 000	300	10	Half-moon	MDC-26s	4-1000207
MDA2203-E+C mini	0.04	0.2	100 - 1 000	300	10	Half-moon		4-1000208
MDA3204-A/TBC	0.4	3.9	150 - 1 500	-	20	Hex 1/4"	MDC-32	4-1050645
MDA3211-A/TBC	1	8.8	50 - 690	-	20	Hex 1/4"		4-1050646
MDA3216-A/TBC	2	13.7	50 - 470	-	20	Hex 1/4"		4-1050647
MDA3236-Q/TBC	4	27	50 - 210	-	20	SQ 3/8"		4-1050648
MDA3264-Q/TBC	8	49	50 - 115	-	20	SQ 3/8"		4-1050649

Delivered without tool cable.

MDC CONTROLLERS

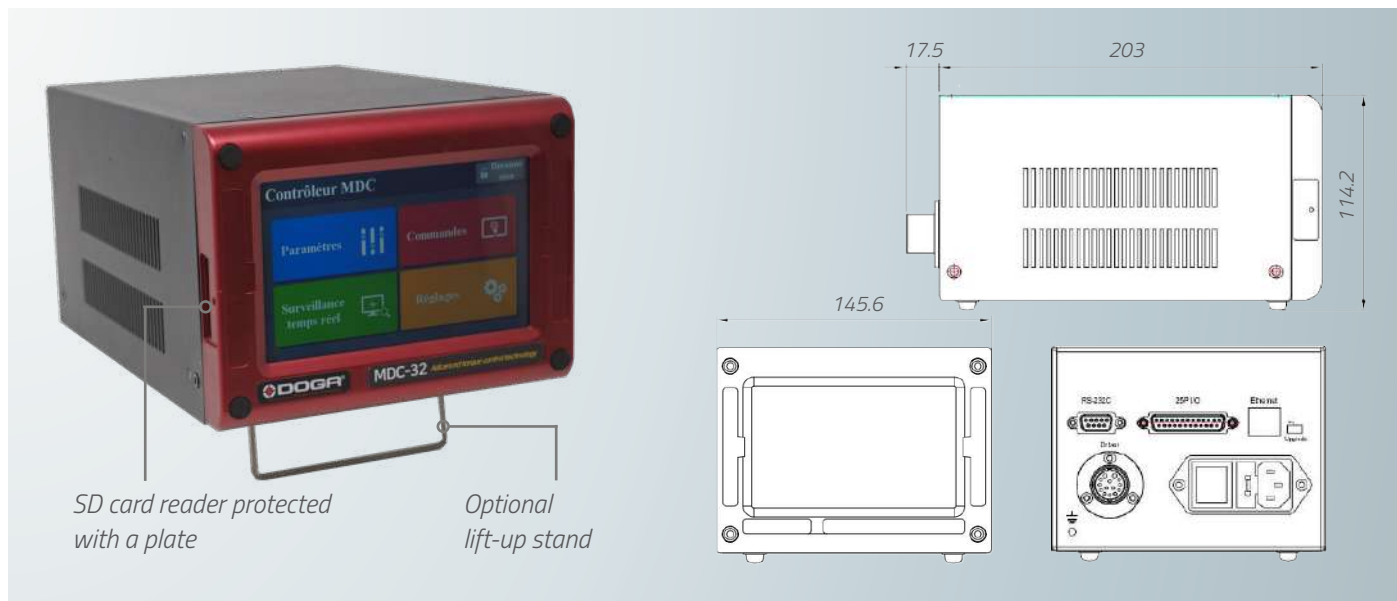

Features of the MDC V2 associated controllers

- Multilingual menus: choice between German, English, Spanish, French, Czech.
- 15 tightening programs (torque and angle control).
- Advanced functions with independent settings for each preset.
4 functions : free reverse rotation, engaging torque detection, thread tapping, angle after torque-up.
- 2 multi sequences programs – for several presets run with one cycle start.
- 15 models of 20 steps with assignable tightening strategies, batch counting, logical IO management.
- Large color LCD touch screen 5" with user friendly graphical interface and full tightening reporting.
- Automatic or manual speed adjustment.
- Self learning mode for tightening parameters optimization.
- Detailed alarm display with error code.
- Integrated web server for parameters set up with a standard web browser.
- Free PC software for programming and real time monitoring called ParaMon.
- Tightening curve display in real time.
- Real time fastening data output.
- RS232 and Ethernet communication ports, Modbus protocol or Open Protocol.
- Preset / Model selection with barcode reader (RS232).
- Built-in card reader and 8 GB industrial SD card included for:
settings, backup and restore - real time fastening data record - controller firmware update.
- 15 inputs / 8 outputs assignable digital IO's.
- ESD Free by body grounding.
- Long life time over 5 million cycles.

Hardware

Voltage	in: AC 230 V, 50/60Hz, 2.5 A / out: DC 38 V 3.5 A
Fuse	2 x T5 A / 230 V
Operating environment	0 ~ 40°C / 15 ~ 80% RH (without dew)
Front panel	5" LCD Color 800 x 480 dots – touch & multilingual menus
I/O	8 inputs and 8 outputs assignable + 7 inputs assigned to models via SUB-D25
SD card	Included one 8 GB SD card- industrial grade
Dimensions and weight	W 146 x H 114 x D 203 mm – 2.5 kg

Software

Management of firmware update	SD Card
Firmware	Controller main board / LCD display
Language	English, French, Spanish, German, Czech
Parameter setting	Controller front LCD / Web Server / Com port, Protocol
Protocol	Modbus, Open protocol
Tightening presets	15 programs consisting of 15 key parameters each
Model	15 models consisting of 20 steps each
Advanced function	4 functions for each preset including free reverse rotation, engaging torque detection, thread tapping, angle after torque up

Controllers

Designation	Suitable for	Code
MDC26s for MD22 CE AC 230 V	MD2201, MD2203	4-1000209
MDC26s for MDA22 CE AC 230 V	MDA2201, MDA2203	4-1000213
MDC26 CE AC 230 V	MD26xx, MDH26xx, MDA26xx	4-1050665
MDC32 CE AC 230 V	MD32xx, MDP32xx, MDH32xx, MDA32xx	4-1050666

Options

Designation	Code
RS232 DB9 cable male/female 3 m	4-1050598
USB to RS232 converter	4-1050597
Modbus / Profinet gateway	Please contact us

Designation	Code
Lift up stand kit	4-1050592
Industrial SD card 8 Gb	4-1290024

Controller communication and display

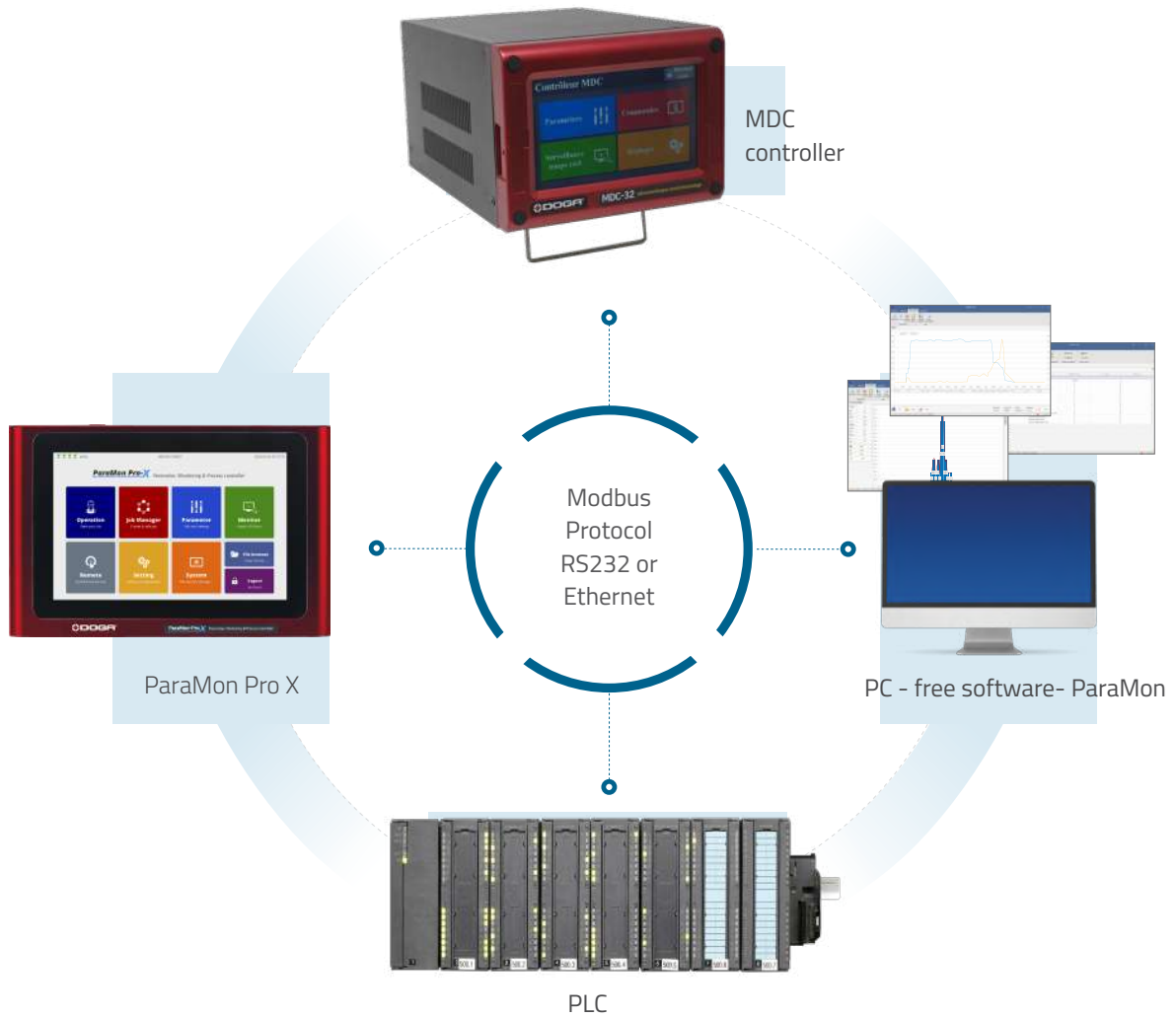

Paramètres

- Théorie
- Comptage
- Contrôleur
- Multi-séquence
- Paramètres avancés
- K / S

Commandes

- Commandes
- Optimisation automatique
- Sauvegarder
- Réinitialiser
- Rodage
- Paramètres par défaut

Réglages

- Date & Heure
- System
- Code de sécurité
- Code de sécurité Clavier
- Minuteur

Operation

- Menu
- Preset 1
- Date and time: 2020-01-21 10:26:55
- Fastening result OK/NOK: OK
- Monitoring torque: 35.32 Kgf.cm
- Torque target: 35
- Speed target/Monitoring: 320 / 319
- Time: 1300
- Monitoring angle: 1150 / 15
- Count target/Monitoring: 5 / 3
- Snug angle: 756

Monitoring

- Graph
- Input & Output
- Network
- Error

Monitoring - Graph

Monitoring - Input & Output

Monitoring - Network

Monitoring - Error

Torque and angle tightening strategies

15 different tightening programs can be set in each MDC controller.
 Each program can be set with 15 customizable parameters.
 Tightening direction may be different for each preset.

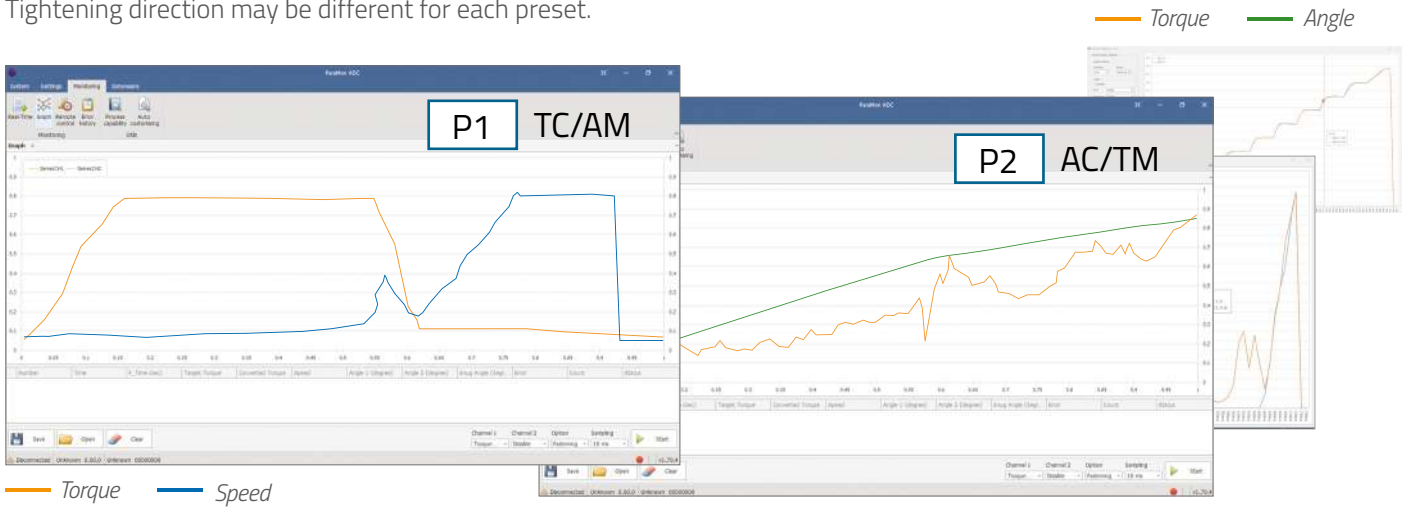

Each preset program has the following customized parameters

- ▶ Tightening mode
 - Torque control + angle monitoring TC / AM
 - Angle control + torque monitoring AC / TM
- ▶ Torque
 - Target torque, min/max torque, snug torque, seating torque, torque compensation
- ▶ Angle
 - Target angle, min/max angle, free speed angle
- ▶ Speed
 - Target speed, free speed
- ▶ Time
 - Soft start time, torque rising time, torque holding time

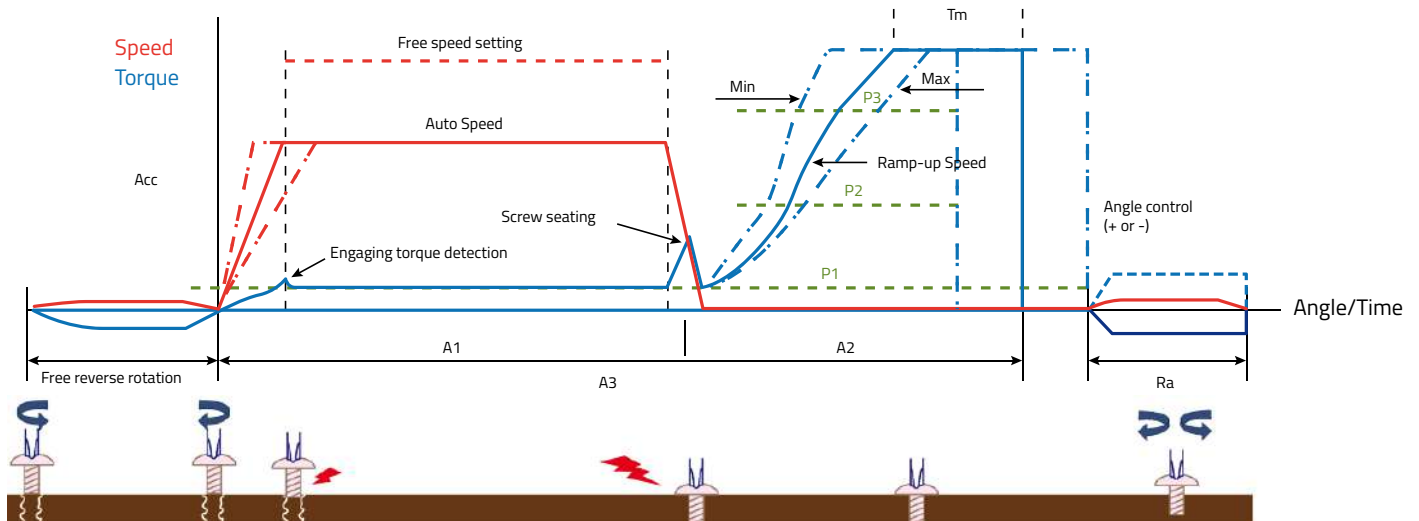

Multisequences programs

- MA and MB allow to chain several programs in a single cycle with a maintained trigger.
- A multisequence can be made up of 10 steps.
- A step is either a program, a loosening or a delay and can be repeated several times.

Example : achieving capability on a test bench.



Easy guidance to the optimized tightening conditions by built-in self customizing simulation feature

Self customizing software will find the optimized parameters to provide torque accuracy for the target torque in fastest speed. Just run tightenings with factory settings until the software stop adjusting parameter settings.

- Optimized speed according to the target torque level.
- Free angle and free speed calculation for fast run down.
- Seating point adjustment.

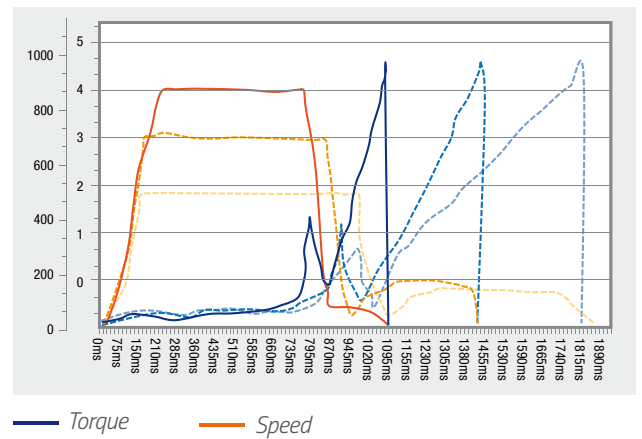

Advanced functions

Consist of 4 usefull advanced functions.

All functions can be set with different parameters for each program.

They meet specific needs such as:

Free reverse rotation to engage screw	Thread tapping to overcome a thread torque higher than target torque	Engaging torque detection to detect a lock nut	Angle after torque up to go reverse for inserts fitting

Models

- With models you can apply Sequence control by managing tightening preset#, screw counting, time delay, inputs & outputs which provide automation without PLC or sequence control device.
- 15 process sequence managing models. Each model consisting with 20 steps of sequence program.
- Each step can control:
 - A tightening batch (TC/AM or AC/TM) with a counter of OK results.
 - An output activation.
 - An Input monitoring.
 - A time delay.
 - A bar code reading.
- A report « model complete » validates the end of the model (sequence end).



Sample program of sequence control

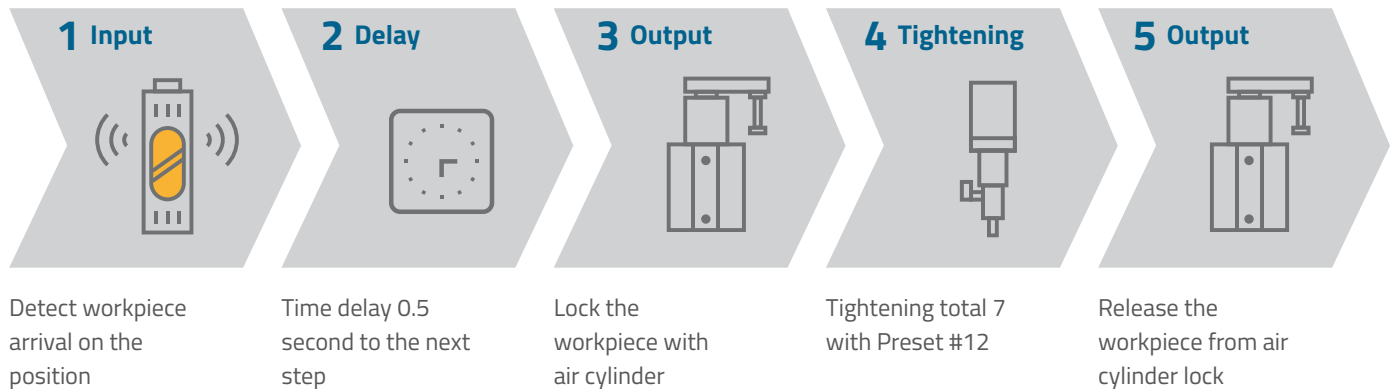

Modbus protocol communication

MDC controller provides the Modbus RTU for RS232 and Modbus TCP/IP for the Ethernet port connection together. The following is available through the communication:

- Parameter read and write
- Data monitoring
- Remote control operation

Modbus RTU

Slave ID	F code	Data	CRC
----------	--------	------	-----

Modbus TCP

Transaction ID	Protocol ID	Length	Unit ID	F code	Data
----------------	-------------	--------	---------	--------	------

PARAMON FREE PC SOFTWARE

MDC controller integrated web server

Without any software preinstalled on your computer access to your MDC controller connected via Ethernet by using your web browser. Just enter the MDC IP address of each controller in a navigation tab.

All functions for parameters setting, saving and monitoring are available.



ParaMon software - free download on www.doga.fr

With Ethernet or RS232 connection, free PC software ParaMon provides easy parameters setting, data monitoring & analysis.

Several windows can be opened at same time to display and edit settings simultaneously.

Multi-channel graph (torque, angle, speed, time) allow a precise analysis of your assembly and settings optimization.

Tightening curves and results can be monitored in real time and saved for later offline viewing.

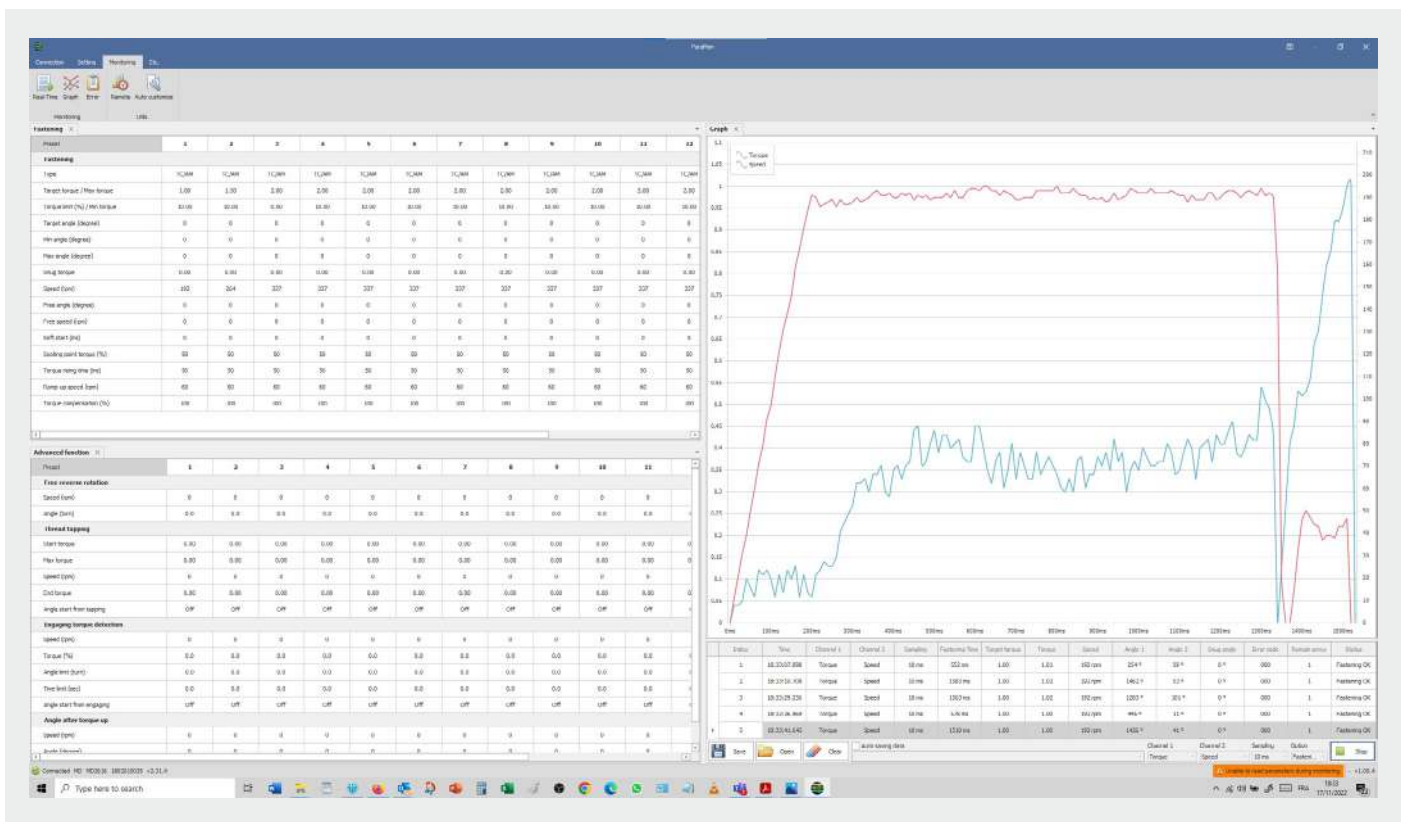

ACCESSORIES AND CALIBRATION

MD screwdriver cables

Cables for MD 22 mini screwdrivers (except MDA22)

Designation	Code
MD mini cable 3 m	4-1000212
MD mini cable 5 m	4-1050753



Standard cables for MDA 22 mini / MD 26 / MD 32 models

Designation	Code
MD cable 3 m	4-1050582
MD cable 5 m	4-1050584
MD cable 8 m	4-1050605



Screwdriver max torque can be lowered by 5% and 20% with extra long 5 and 8 meters cables.

Reinforced cables for MDA22 mini / MD26 / MD32 models

Reinforced cables are highly recommended for angle and pistol screwdrivers applications.

Designation	Code
MD reinforced cable II 3 m	4-1050661
MD reinforced cable II 5 m	4-1050662
MD reinforced cable II 8 m	4-1050663



Screwdriver max torque can be lowered by 5% and 20% with extra long 5 and 8 meters cables.

Special connectors

Designation	Code
90° connectors L 70 mm Position not adjustable	4-1004931
Cable extension connector F/F	4-1050719



90° connector



Extension connector

Telescopic bit cushion (TBC)

Designation	Suitable for	Code
MDA telescopic bit cushion Hex 1/4" [TBC 3204-16-A]	MDA 3204, MDA3211 MDA3216	4-1050650
MDA telescopic bit cushion SQ 3/8" [TBC 3204-16-Q]	MDA3204, MDA3211 MDA3216	4-1050651



Air vacuum systems

Designation	Code
Vaccum system half-moon M16	Please contact us
Vaccum system Hex 1/4" M20	
Vaccum system Hex 1/4" M23	
Vaccum system half-moon M20	
DELVO® vacuum pump DLP2570	

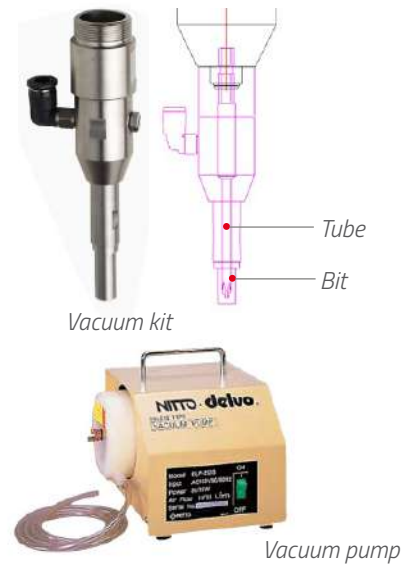

Bit holder assy

Extra bit holder with bearing provide better bit concentricity..



Designation	Suitable for	Bit socket	Bit length*	Code
Bit holder assy \varnothing 4 mm M16	MD2201, MD2203-E	\varnothing 4 mm	44 mm	4-1000141
Bit holder assy \varnothing 4 mm M20	MD26xx-E	\varnothing 4 mm	64 mm	4-1050588
Bit holder assy \varnothing 7 mm M20	MD26xx-A, MD3201-A, MD3202-A	\varnothing 7 mm	70 mm	4-1050586
Bit holder assy Hex 1/4" M20		Hex 1/4 "	70 mm	4-1055188
Bit holder assy \varnothing 4 mm M23	MD3204 to MD3216	\varnothing 7 mm	70 mm	4-1050587
Bit holder assy Hex 1/4" M23		Hex 1/4 "	70 mm	4-1055189

*Bit not included

Torque ring holders for straight screwdrivers

Anodized aluminium ring for bottom mounting on a torque arm.

Designation	Suitable for	Code
Torque ring holder ø 36	MD2601 ~ 16	4-1000177
Torque ring holder ø 41	MD3201 ~ 16	4-1000176
Torque ring holder ø 43	MD3236 ~ 64	4-1000158



Auxiliary handle for pistol tools

Designation	Suitable for	Code
Handle for side reaction grip	MDP3204 ~ 3216	4-1050744



Swivelling clamp for angle head nutrunners

Made of anodized aluminium with adjustable center of gravity.

Easy rotation thanks to the ball bearing assembly.

Balancer and snap hook are not included.

Designation	Suitable for	Code
Swivelling clamp ø 41	MDH3204 ~ 3216	4-1000217
Swivelling clamp ø 43	MDH3236 ~ 3264	4-1000218



Torque calibration service for torque and angle control tools

Service carried out in our premises.

- Machine capability test $C_m/C_{mk} > 1.67$ with a tolerance of $\pm 10\%$ on the delivered torque.
- Calculation of the measurements average, standard deviation and machine capability C_m/C_{mk} on 25 measurements.
- Adjustment of the screwdriver calibration and/or torque compensation if needed.
- Test report.

Designation	Code
Machine capability report for 1 torque value (by default 80% of max torque)	4-7502783
Machine capability report for 3 torque values (20%, 50%, 100% of max torque)	4-7500315

ADDITIONAL PRODUCTS

RS232 bar code reader for MDC controller

To select preset or model.

Bar code is merged to tightening datas on SD memory card or read over Modbus protocol.

Wired version

- Handheld laser scanner, durable lightweight
- Easy settings without software



Wireless version

- For 1D bar codes, including high-density



Designation	Specification	Code
Handheld 1D laser scanner wired - serial connection to MDC	Wired scanner RS232 + power supply 230 V 50 Hz + stand	4-5000320
Wireless 1D laser scanner serial connection to MDC	Wireless scanner + cradle RS232 cable 2 m Power supply	4-5001118 4-5000428 4-5001180
Wired 1D / 2D laser scanner Ultra rugged and programmable	Wired RS232 scanner only RS232 cable 2 m Power supply for RS232 cable	4-5000427 4-5000428 4-5000429
Null modem adapter MDC*	Sub-D 9 P "crossed wire" M/F	4-3100211
Gender changer M/M MDC*	Sub-D 9 P M/M	4-3100212



* Necessary to adapt scanner RS232 to MDC controller serial port.

I/O BOX: wiring box SUB-D44

Output port has the relay contact with the max. 1 A capacity for each port.

Be sure that the 24 V DC power supply should have enough capacity for total output load.

Designation	Code
44 P I/O box	4-1050593
I/O cable/MDC controller	4-1050595
DC adapter + power cable	4-1050599



The 7 inputs of the MDC V2 dedicated to models cannot be connected to I/O box.

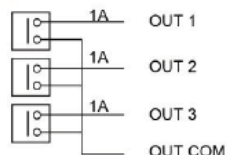

BS-5C color ID bit tray

This innovating bit box ensures the fit between the bit and the tightening program.

It can be used in two ways: it either tells the operator which bit to use to perform the assembly operation, or it selects the tightening program associated with this bit when the operator takes a tightening bit.

Its self-learning configuration does not require machining or factory setting like most bit boxes on the market.

Keying is assured in an absolute way by color recognition.

Designation	Code
BS-5C color ID bit tray	4-3200100



Delivered without bit holder
Including power supply 100-240 V 1 A / 24 VDC
and a first set of 20 heatshrink sleeves
Dimensions (WxHxD): 280 mm, 62 mm, 170 mm



LCD bit socket tray with magnet sensor

4 available models from 4 slots to 16 slots to lay flat on a small foot print.

Assignment of socket no and screwdriver Preset# can be direct 1 to 1 matching or flexible.

Steelbit detection by inductive sensor.

Designation	Code
BST-4 LCD	4-1290027
BST-8 LCD	4-1290028
BST-12 LCD	4-1290029
BST-16 LCD	4-1290030



Delivered without bit holder
Voltage 24 V DC 1 A
External adapter 230 V / 24 V DC included
Dimensions (WxHxD): 220 x 55 x 170 mm (BST-8 LCD)



ParaMon Pro X controller



- Up to 8 MD or BM tools connected at once.
- Parameters setting and data monitoring.
- Job manager: error-proofing through assembly sequencing and process monitoring.
- Fastening data auto saving in daily files.
- Tool remote control.
- Unlimited extension of preset settings in job mode.
- Possibility to interrupt and continue later any job.

Features

Input power	AC 220 - 240 V, 50/60 Hz, 0.35 A
Dimensions (WxHxD)	300 x 196 x 80 - Wall mount bracket included
Display	10.1" TFT LCD Touch
Com port	Ethernet, 2 x USB, I/O (input 16 TOR, output 16 TOR), RS232 (barcode reading or USB key or bit socket tray)
Memory	Internal: 8 GB + extra memory slot with file system External: micro SD card up to 32 GB (micro SD card not included)
Wifi	Wireless USB adapter 2.4 & 5GHz Plug-in dual channel module kit
Display extension	HDMI
Weight	3.54 kg

Designation	Code
ParaMon Pro X	4-1050685

OUR SERVICES

At DOGA we put at your disposal our reliable, accurate and user friendly tightening solutions. It is our duty to advise you of the right solution for your application.

Our Product Manager and Support engineering teams are here to analyse your manufacturing process and share with you our innovative solutions to improve your assembly process.

Thanks to our technical integration service CELPRO, we provide you with turnkey solutions from design to commissioning.



TURNKEY SOLUTIONS

Using all the options of our complete products range, we offer you solutions adapted to your needs.

- ▶ Custom Design
- ▶ Adaptation of existing models
- ▶ Integration of automation system



TECHNICAL ASSISTANCE

To ensure the optimal performance and durability of our tools, we put our technical assistance at your disposal.

- ▶ Installation and start-up
- ▶ Maintenance agreement
- ▶ On-site maintenance
- ▶ Maintenance in our workshop



TRAINING

DOGA offers specialized training courses around its trades:

- ▶ Theoretical
- ▶ Technical & practical
- ▶ Audit & consulting

RELATED PRODUCTS



Torque reaction arms and tool positioning systems

The widest range of reaction arms to meet your various demanding requirements.

> [Learn more about our torque reaction arms](#)



Sockets, bits and accessories

Wherever they are tightened, screws and nuts of all shapes and materials can be matched with their sockets, bits and other accessories, forged from the best steels and regularly checked, they offer constant quality.

> [Learn more about our sockets, bits and accessories](#)



Screw feeding

Reduce your cycle times with our automatic screw feeding systems.

> [Learn more about our screw feeding systems](#)



Air vacuum systems

The air vacuum screw gripping system meets your non-magnetic or small screw assembly needs.

> [Learn more about our air vacuum systems](#)



Find all our ASSEMBLY TECHNOLOGY products on our website by scanning this QR code

